

Hollow Rotating Platform



The hollow rotating platform can be driven by different brand servo motors with high precision. The operation is stable and the positioning is precision.

GEARKO[®]

DRIVES

THE PRECISION



TMN Series

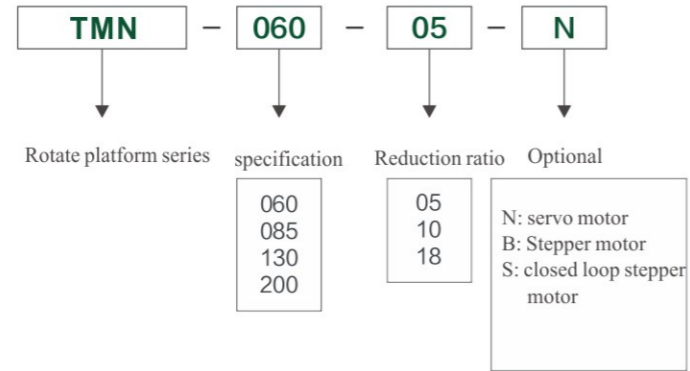

TMN130

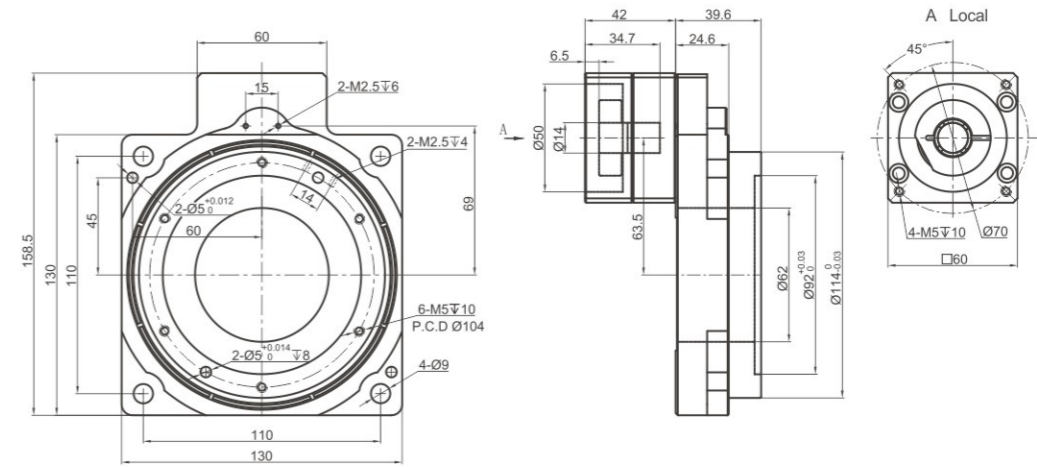

TMN060

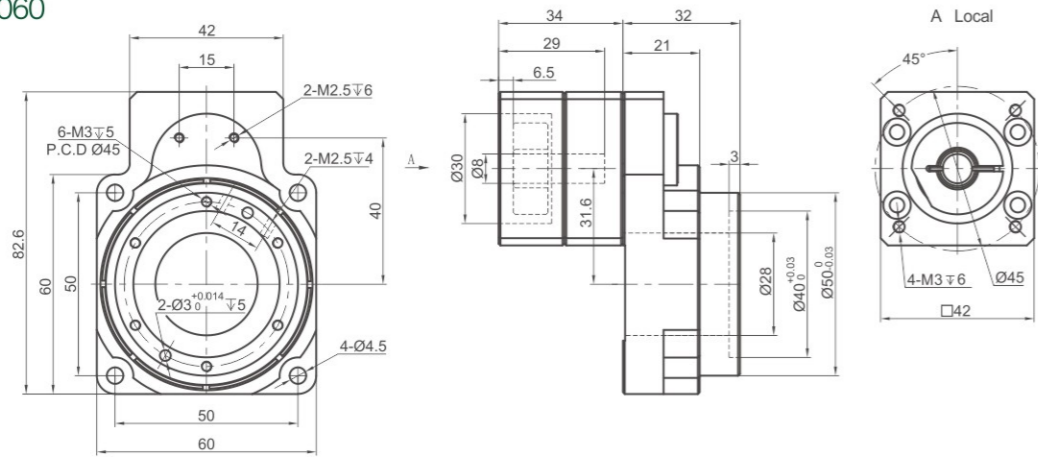

TMN200

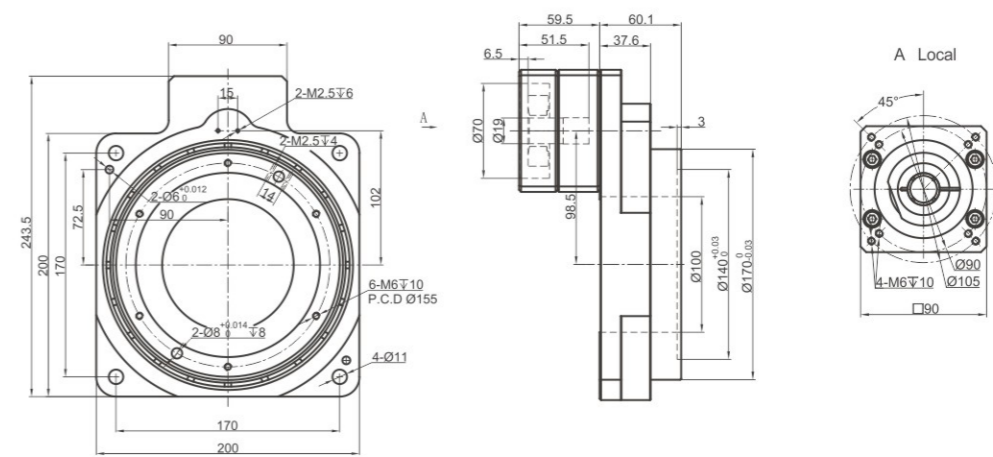

TMN085

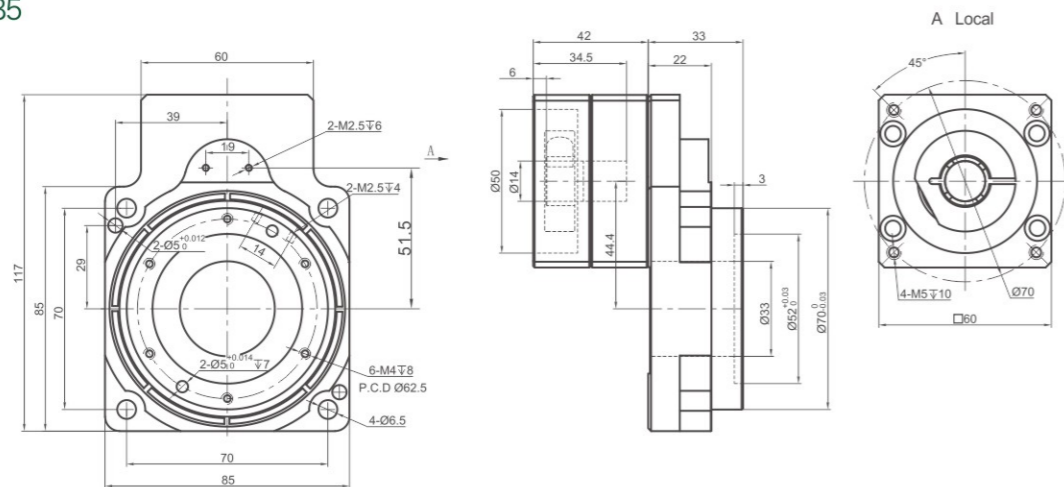

		TMN60		TMN85		TMN130		TMN200	
Speed Ratio		5	10	5	10	10	18	10	18
Matching Servo Motor	W	50~100		200~400		200~400		750	
Bearing Type		Crossed Roller Bearing		Crossed Roller Bearing		Crossed Roller Bearing		Crossed Roller Bearing	
Allowable Torque	N.m	53		20		16		32	
Allowable Disk Output Speed	rpm	200		300		250		250	
Allowable axial load	N	250		500		2000		4000	
Repeat Positioning Accuracy	arcsec	±10		±10		±10		±10	
Positioning Precision	arcmin	3		3		3		3	
Flatness of Rotating Platform	mm	0.01		0.01		0.01		0.01	
Outside Diameter Runout of Output End	mm	0.01		0.01		0.01		0.01	
Service Life	h	20000		20000		20000		20000	
Noise	dB	≤65		≤65		≤65		≤65	
Backlash	arcmin	≤1		≤1		≤1		≤1	
Protection Class		IP40		IP40		IP40		IP40	
Weight	kg	1.2		1.8		2.5		8	

The above technical parameters are for reference only. Actually, according to the data provided by the customer, relevant technical parameters and dimensions will be issued.
Origin Sensor Kit: TMN Series with OMRON EE-SX674